

HC-Sinus Slide®

Repair Joint



STEEL QUALITY	EN 10025 - S235, cold drawn NBN A 24-302 - BE 500 TS EN 10111:2008 - DD14
MATERIAL THICKNESS	2 x 5 mm (13/64")
PROFILE LENGTHS	3,00 m (+5 / -10 mm) (9.84 ft +13/64" / - 25/64")
JOINT OPENNING	Optimal up to 15 mm (19/32")
ANCORAGE STUDS	3 mm (1/8") flat rectangular bar for connecting of anchorage bolts, distance 243 mm (9 9/16") + Ø6 mm (15/64") U-shaped horizontal stirrups
VERSIONS	Black steel / galvanized / stainless Pre-opening with polyethylene foam 5 mm (13/64") Optional, installation and levelling help available

Height [mm] (inch)	Weight [kg/m] (lbs/ft)	Weight [kg/pc] (lbs/pc.)	Quantity [pcs./pal.]	Quantity [m/pal.] (ft/pal.)	Gross weight [kg/pal.] (lbs/pal.)
35 (1 3/8)	4,31 (2.90)	12,93 (28.51)	70	210 (689)	955 (2105)
50 (1 31/32)	5,66 (3.80)	16,99 (37.46)	70	210 (689)	1240 (2734)
60 (2 23/64)	6,48 (4.35)	19,44 (42.86)	70	210 (689)	1410 (3109)
70 (2 3/4)	7,57 (5.09)	22,70 (50.04)	70	210 (689)	1640 (3616)
80 (3 5/32)	8,49 (5.71)	25,46 (56.13)	70	210 (689)	1830 (4034)

Other heights and custom solutions are possible upon request.

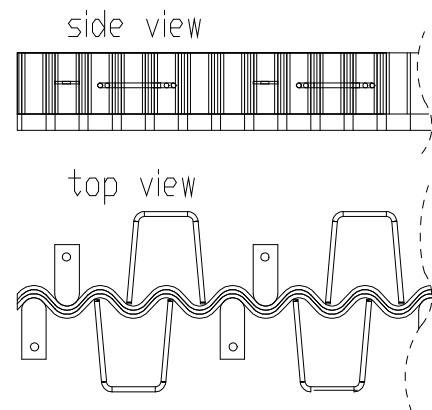
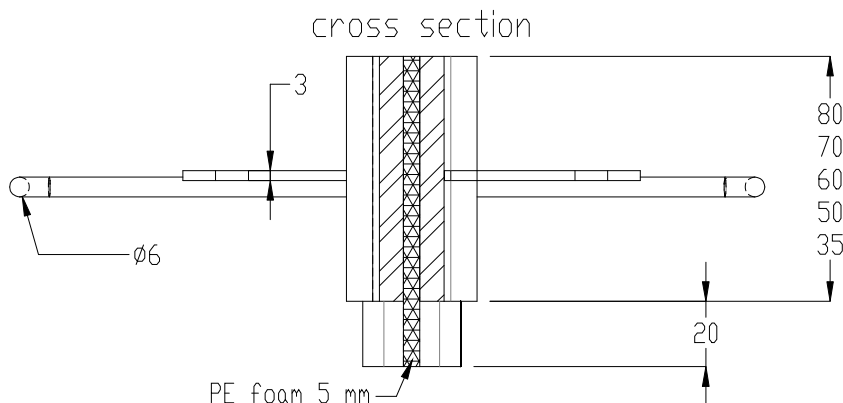

Document issued January 2020. Hengelhoef Concrete Joints nv. reserves the right to alter the products without notice.
©COPYRIGHT 2020 by Hengelhoef Concrete Joints nv.



HENGELHOEF
CONCRETE JOINTS

Hengelhoefstraat 158, Poort Genk 0420, B-3600 Genk
T. +32 (0)89 32 39 80 · F. +32 (0)89 32 39 88
E. info@hcjoints.be

www.hcjoints.be